

SAFE WORK PRACTICES LIFTING WITH EYE BOLTS

**This information does not take precedence over OH&S. All employees should be familiar with the Saskatchewan Employment Act and the OH&S Regulations.*

Use plain or shoulderless eye bolts for vertical loading only. Angle loading will bend bolts.

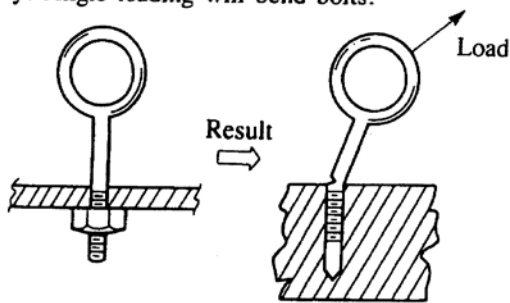

Use shoulder eye bolts for vertical or angle loading.

Pack with washers to ensure that shoulder is firmly in contact with surface.

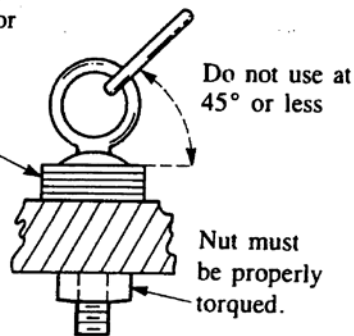

Incorrect. When the load is applied to the eye in this direction it will bend.

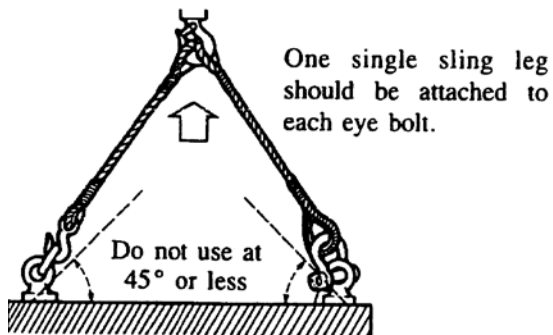
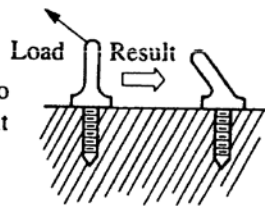

CHECK-LIST

DO:

- ENGAGE at least 90% of threads in receiving hole when using shims or washers.
- INSPECT and clean the eye bolt threads and the hole.
- SCREW the eye bolt on all the way down and properly seat.
- ENSURE the tapped hole for screw eye bolts (body bolts) has a minimum depth of 1 1/2 times the bolt diameter.
- INSTALL the shoulder at right angles to the axis of the hole.

DO NOT:

- DO NOT PUT a sling through eye bolts.
- DO NOT GRIND, machine or stamp eye bolts.
- DO NOT PAINT an eye bolt. This could cover up flaws.
- DO NOT USE eye bolts which have worn threads or other flaws.

